

# Subjects to Discuss

## How to Apply Cloud Computing

during our visit to IBM on 10/13th, 2009

- **Global University System (GUS)**  
<http://tinyurl.com/sfgm7>
- **Globally Collaborative Environmental Peace Gaming (GCEPG)**  
<http://tinyurl.com/k2c7a>
- **Global Early Warning System (GEWS) as the extension of GCEPG project**
- **IBM's possible support of iLab Consortium and a pilot project to verify Al Gore's proposition**  
<http://tinyurl.com/yckvqtp>  
<http://tinyurl.com/yermnpx>

## University: Leader of Community in the Knowledge Society in the 21st Century

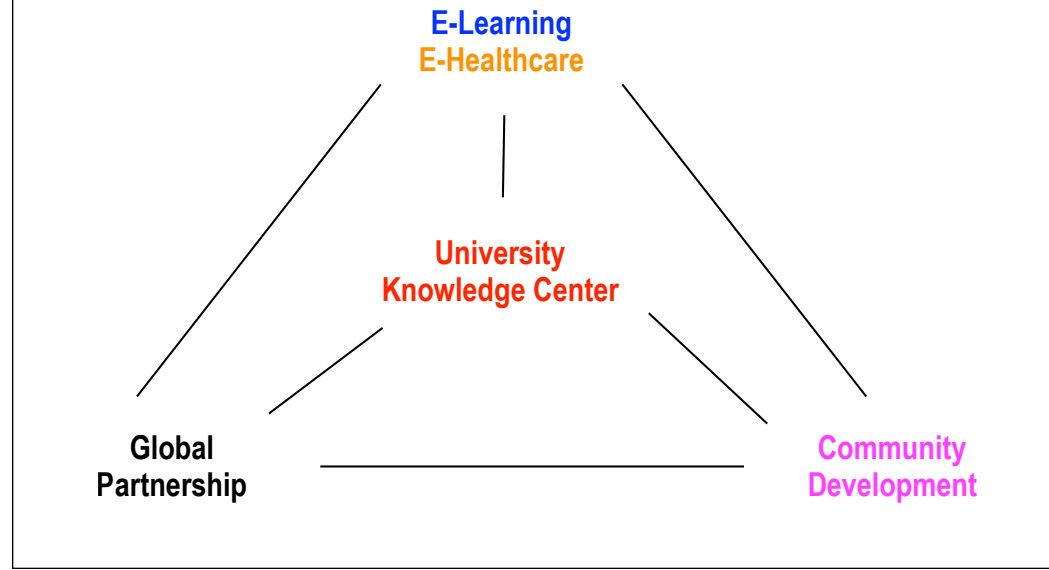

2

The word "University" has a connotation of "universe." Hence, the university in remote/rural areas of developing countries ought to act as the knowledge center of their community for the eradication of poverty and isolation through the use of advanced Information and Communication Technologies (ICTs).

The university has to provide not only e-learning and e-healthcare services to their community, but also to lead their community development.

It also ought to be the gateway for globally collaborative research and development as fostering the Global Creative Economy in the borderless Knowledge Society of the 21st century.

Mission of GUS: GUS aims to build a higher level of humanity with mutual understanding across national and cultural boundaries for global peace.

The GUS helps higher educational institutions in remote/rural areas of developing countries to deploy broadband Internet in order for them to close the digital divide.

The GUS education thus will promote world prosperity, justice, and peace, based on moral principles rather than political or ideological doctrines. The aim is to achieve "education and healthcare for all", anywhere, anytime.

Goal of GUS: The GUS is a world-wide initiative to create broadband Internet infrastructure and educational programs for access to educational resources across national and cultural boundaries for global peace.

Education and job skills are the keys in determining a nation's wealth and influence.

Activities of GUS: GUS has group activities in the major regions of the globe in partnership with higher learning and healthcare institutions. They foster the establishment of GUS in their respective regions, with the use of an advanced global broadband Internet virtual private network. Those institutions affiliated with GUS become members of the GUS/UNESCO/UNITWIN Networking Chair Program located at the University of Tampere in Finland.

Students in these regions will be able to take their courses, via advanced broadband Internet, from member institutions around the world to receive a GUS degree.

These students and their professors from participating institutions will form a global forum for exchange of ideas and information and for conducting collaborative research and development with the use of emerging GRID networking technology.

# Subjects to Discuss

## How to Apply Cloud Computing

during our visit to IBM on 10/13th, 2009

- **Global University System (GUS)**  
<http://tinyurl.com/sfgm7>
- **Globally Collaborative Environmental Peace Gaming (GCEPG)**  
<http://tinyurl.com/k2c7a>

**Iron Rule #1 of Simulation**

**Make Simulation  
close to SIMULAND  
as much as possible.**

## Globally Collaborative Environmental Peace Gaming (GCEPG)

Structure of Integrated Models and Communication Network  
Boxes are dispersed, dissimilar computers around the global Internet.

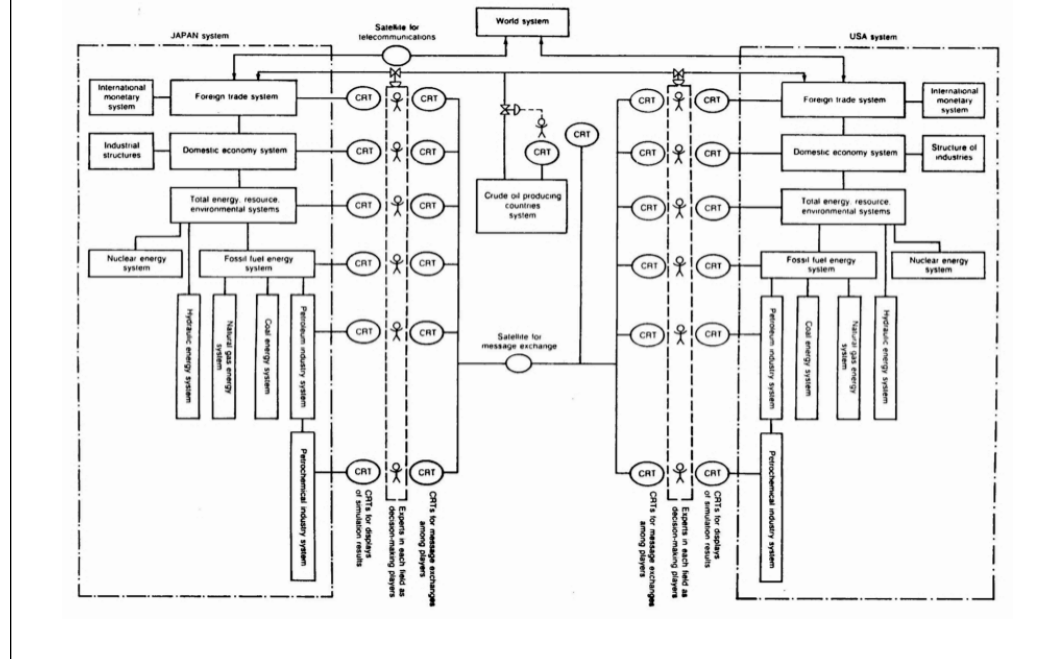

5

## Global Peace Gaming for Oil Crisis

I once proposed a global peace gaming to cope with the oil crisis in early 1970s in response to Meadows' "Limit to the Growth." An outline of the hierarchical structure and distributed components of an integrated, interactive peace gaming/simulation system for energy, economics, and foreign trade in the USA and the Japanese sides was depicted in this diagram. Each block in the figure represented dissimilar computers in those countries interconnected through data telecom network (e.g., Internet nowadays). These computers included simulation models designated in each block. All models would be executed in concertedly via satellite and terrestrial telecommunication links.

## Growth of Japanese Petrochemical Industry

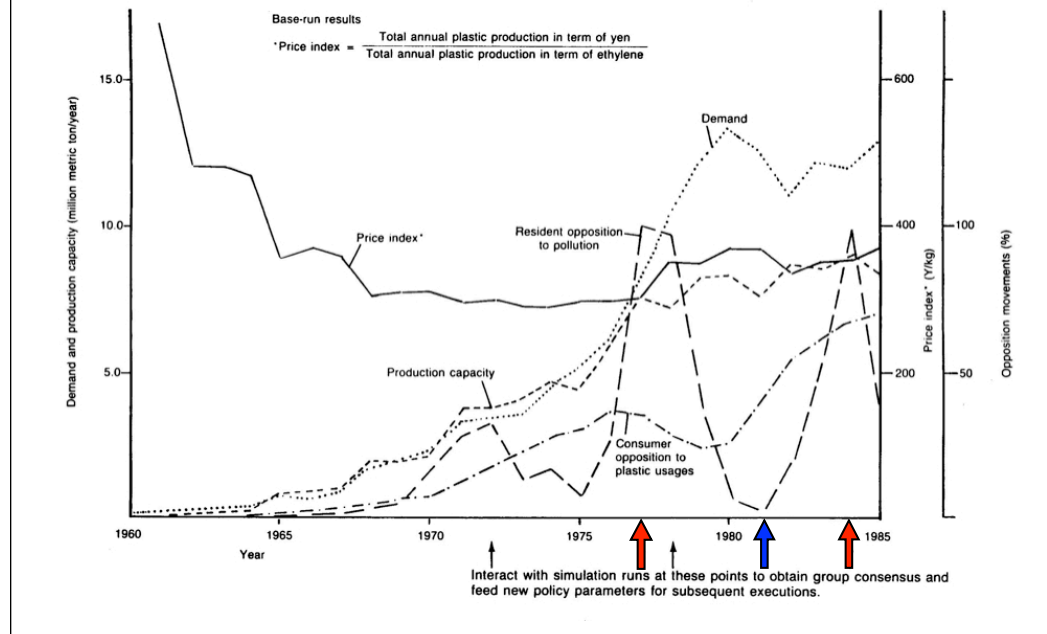

6

For example, suppose pollution in Japan exceeded a certain allowable level, say, around 1977 on this graph, the Japanese expert watching it on the display unit would stop the entire simulation. All participants, wherever they were located, would then try to find, with the use of the conferencing system, a consensus on a new set of pseudo-alternative policy parameters which would be executed until a new crisis appears, say, around 1984 on the figure. The process would be repeated for rational policy analysis, based on facts and figures, and with international cooperation of experts in both countries.

# Deregulation of Japanese Telecom Policy for the Use of Email



UNITED STATES DEPARTMENT OF COMMERCE  
International Trade Administration  
Washington, D.C. 20230

APR 6 1982 **April 6 1982**

Dr. Takeshi Utsumi  
Global Information Services  
43-23 Colden Street  
Flushing, N.Y. 11355

Dear Dr. Utsumi:

Enclosed are three cables from the U.S. Embassy in Tokyo reporting on the recent move by the Ministry of Posts and Telecommunications (MPT) to remove the usage restrictions on the ICAS system.

According to the Embassy, MPT's action will allow Global Information Services to offer electronic mail, computer conferencing, and word processing services to Japanese customers via the ICAS system. It thus appears that Global's TFC case has been favorably resolved. ← **Electronic Mail**

Please review the enclosed cables and let me know your reaction. If you have no objection, we will close this case.

Sincerely,

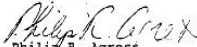
  
Philip R. Agness  
TFC Staff Officer

Enclosures (3)

# Initiation of GRID Concept

## Excerpt from

**SIMULATION IN THE SERVICE OF SOCIETY (S3)**, Simulation, September 2000

**John McLeod** A Technical Editor

**Suzette McLeod** A Managing Editor

## **Power (?) Grid!**

As readers may have noticed, this writer has been interested in the desirability/possibility of someone, or some agency, developing a global communication network since my first discussing the matter with **Tak Utsumi** in **1972**. At the time Tak and I were both primarily interested in the use of such a network for the **distributed simulation of "Peace Gaming,"** as contrasted with the war games so widely used by the military of all countries. However, my early enthusiasm had to be redirected from personally contributing to such an undertaking when I realized the enormity of the technical problems. But **Tak has persevered and has successfully demonstrated many components of a necessary infrastructure.**

Tak and his colleagues have had to raise funds from any sources that they could, as well as pushing back the technical frontiers. But recently several powerful publicly funded organizations have entered the picture. NASA of course has a worldwide communication network which is necessary in support of its space program. However, I understand--perhaps mistakenly--that it is to be made available commercially. More on that when I learn more.

And now we have the following article describing a communication network which it seems to me is misnamed, and I wonder how many others, think of a power grid as a network for the distribution of electrical power. Be that as it may, the description seems to be that of an information network, and the list of participants seems to indicate that it is supported largely by the National Science Foundation. -JM

## **Building an Information Power Grid ....**

<http://makeashorterlink.com/?H241159B9>

## Globally Collaborative Environmental Peace Gaming (GCEPG)



9

E-mail and multimedia World Wide Web of Internet so far contributed significantly to the world society on the dissemination of information. The next phase of the Internet development with global neural (or GRID) computer networks should be the globally collaborative experiential learning and constructive creation of wisdom with interactive actions on virtual reality simulation models of joint global research and development projects on various subjects.

Globally Collaborative Environmental Peace Gaming through  
Global Neural Computer Network

- Need: Kyoto Protocol
- Computer Simulation Models
  - Socio-Economic-Environment Model
  - Climate Simulation Model
- Beowulf Mini Supercomputer
  - Maui Community College in Hawaii
- Global Neural (Grid) Computer Network

This will promote trustful friendship among youngsters around the world to realize the Knowledge Society of the 21st century, and their collective creativity will enlarge the size of pie for stakeholders to reach peaceful win-win consequences. Senator Fulbright once said that learning together and working together are the first steps toward world peace.

# Subjects to Discuss

## How to Apply Cloud Computing

during our visit to IBM on 10/13th, 2009

- **Global University System (GUS)**  
<http://tinyurl.com/sfgm7>
- **Globally Collaborative Environmental Peace Gaming (GCEPG)**  
<http://tinyurl.com/k2c7a>
- **Global Early Warning System (GEWS) as the extension of GCEPG project**

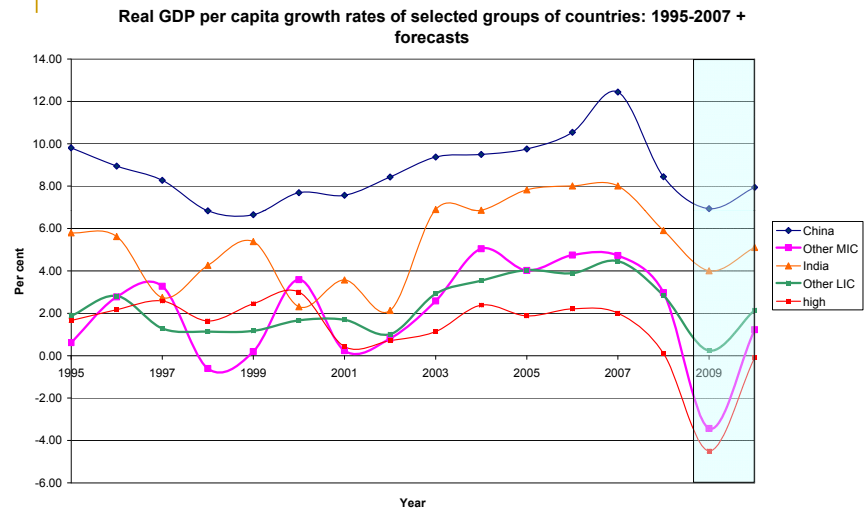

Paris School of Economics

18

[http://www.ony.unu.edu/Dr.Bourguignon\\_Crisis\\_UN\\_presentation.pdf](http://www.ony.unu.edu/Dr.Bourguignon_Crisis_UN_presentation.pdf)

# Subjects to Discuss

## How to Apply Cloud Computing

during our visit to IBM on 10/13th, 2009

- **Global University System (GUS)**  
<http://tinyurl.com/sfgm7>
- **Globally Collaborative Environmental Peace Gaming (GCEPG)**  
<http://tinyurl.com/k2c7a>
- **Global Early Warning System (GEWS) as the extension of GCEPG project**
- **IBM's possible support of iLab Consortium and a pilot project to verify Al Gore's proposition**  
<http://tinyurl.com/yckvqtp>  
<http://tinyurl.com/yermnpx>