

DEVELOPMENT RESULTS OF ON-BOARD BASEBAND SWITCH EM FOR WINDS

N. Yoshimura*, N. Kadowaki**, Y. Ogawa*, Y Hashimoto*, R. Suzuki*

*National Institute of Information Communications Technology, Japan

** ATR Adaptive Communications Research Laboratories, Japan

4-2-1 Nukui-Kitamachi Koganei, Tokyo, 184-8795, Japan

Tel: +81-42-327-5336 Fax: +81-42-327-6825 e-mail: naoko@nict.go.jp

Introduction

For several years, the National Institute of Information Communications Technology (NICT, formerly CRL) has been engaged in the research and development of a very high data satellite communications system known as the “Gigabit Satellite Project”. The results of this work are being used in the development of a wideband internetworking engineering test and demonstration satellite (WINDS), an experimental satellite which is currently being developed by the Japan Aerospace Exploration Agency (JAXA, formerly NASDA) and NICT. NICT is in charge of developing the ATM-based baseband switching subsystem (ABS) for the WINDS project. In 2002, we made a bread board model (BBM) and the results were used in the development of an engineering model (EM).

We have now completed testing and evaluation of each subsystem component of the EM and in this paper we present the results.

WINDS system

WINDS has three operating modes: a regenerative mode, bent-pipe mode, and regenerative/bent-pipe hybrid mode. The ABS is used in the regenerative mode. The configuration for the WINDS mission is shown in Fig. 1.

We used a TDMA scheme as the access control method for WINDS. The structure of the TDMA is shown in Fig. 2.

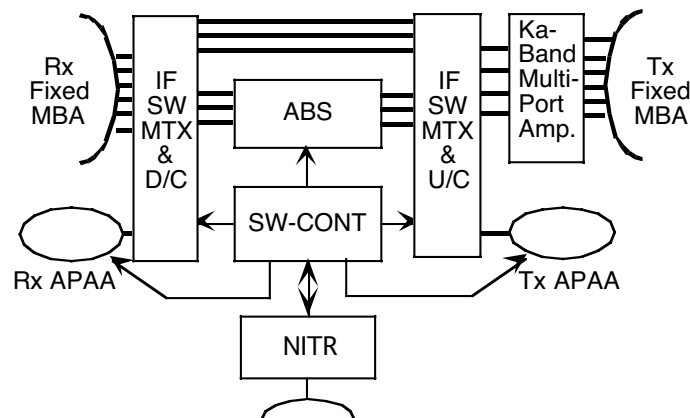

Fig. 1 Configuration for WINDS mission

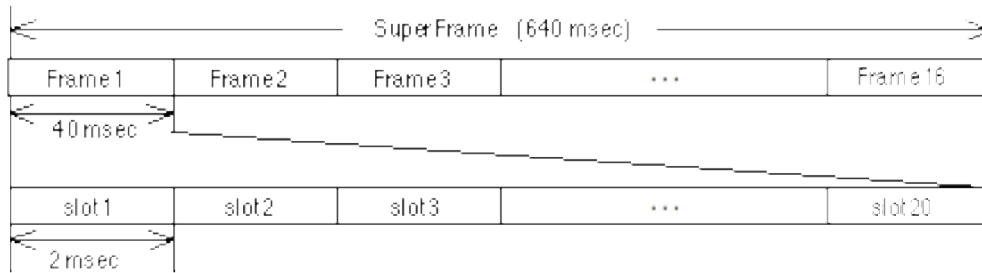

Fig. 2 Structure of TDMA scheme for WINDS

ABS

The ABS enables high-speed, highly efficient regenerative switched connections between several beams. Not all ATM switching functions will be on-board WINDS. Although some network control functions need to be on-board, others can be installed in the network control station (NCS) on the ground. The on-board functions will carry out cell switching based on a switching table generated by the NCS according to user requests.

Configuration

The ABS has three components: a DDEM (digital signal processing type demodulator), MOD (modulator), and ATMS (ATM switch). The on-board configuration of the ABS includes a set of three DDEMs, three MODs, and two ATMS. A block diagram of the ABS's functions is shown in Fig. 3. We developed a DDEM, a MOD, and an ATMS for the ABS EM.

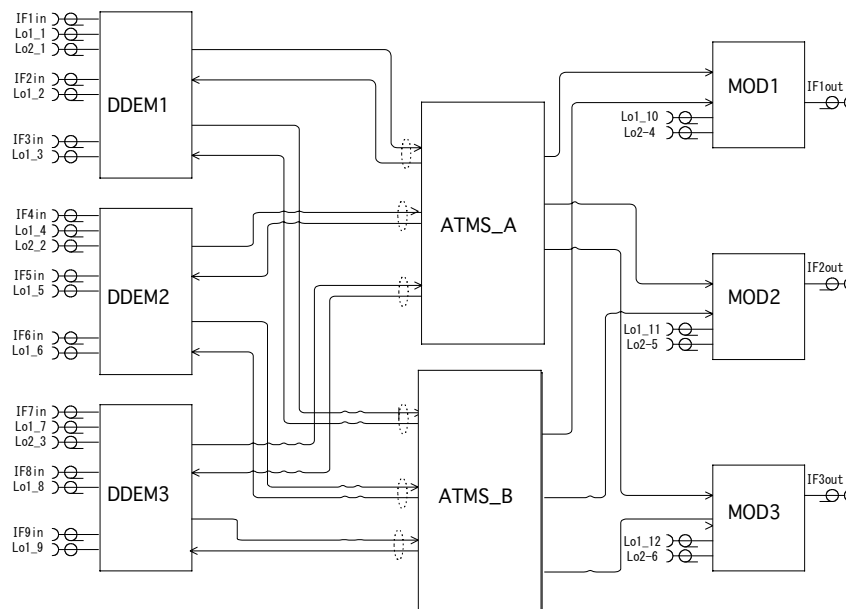

Fig. 3 Configuration of ABS

Testing and evaluation

Component testing

i) DDEM

The DDEM is based on digital signal processing technology and one DDEM component consists of three independent demodulator units. Each unit can handle three data rates (1.5/6/24/51 Mbps) in a TDMA burst format. One DDEM component, consisting of three demodulator units, can demodulate a 155-Mbps data stream by parallel processing using three carriers with 51-Mbps data rate signals. Another notable feature of the D-DEM is the frequency demultiplexing function, which provides multiple 1.5-Mbps data rate channels. As a result, one demodulator unit is able to provide 14 channels at a data rate of 1.5 Mbps within the bandwidth for a 51-Mbps data rate channel.

Tests of this component showed that the DDEM EM accurately performed demodulation and TDMA synchronization at the all data rates.

The BER characteristics were required to satisfy a specification for $BER < 1E-10$ by $E_b/N_0 > 10$ dB with an error correction code of RS(255,223). However, it was very difficult to measure the BER characteristics with an error correction code. It was also time consuming because the ABS handles a higher data rate. The BER was therefore measured without the error correction code. The test condition was $BER < 2E-4$ by $E_b/N_0 > 10$ dB. At all data rates, the DDEM EM satisfied the above specification. The results of measuring the BER characteristics are shown in Fig. 4. In the figure, rate 0 indicates the 1.5-Mbps data rate. Similarly, rates 1, 2, and 3 indicate 6, 24, and 51 Mbps, respectively.

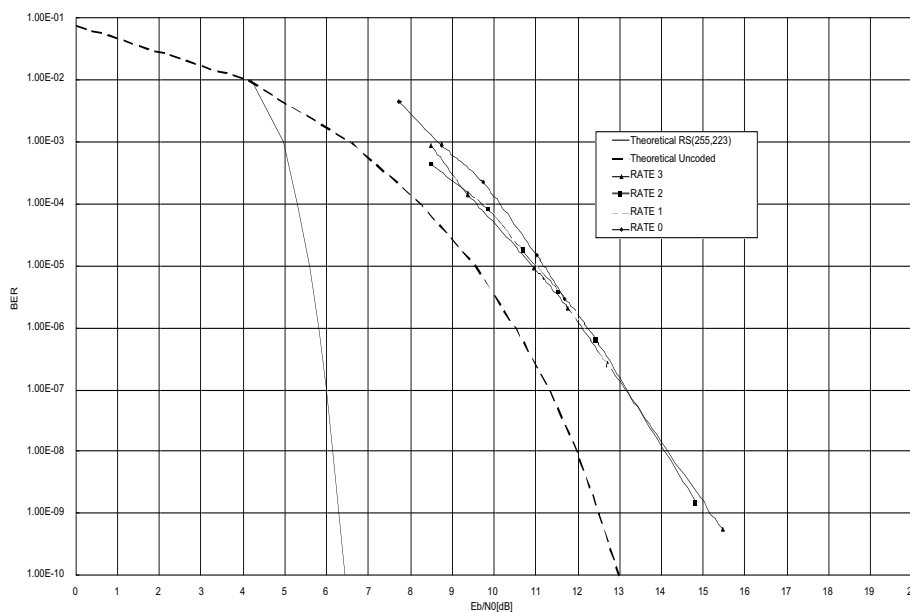

Fig. 4 BER characteristics for DDEM EM

In addition, its dynamic range was found to exceed 20 dB at all data rates.

This component weighs 22 kg and has a power consumption of about 113 W. The power consumption trend is shown in Fig. 5.

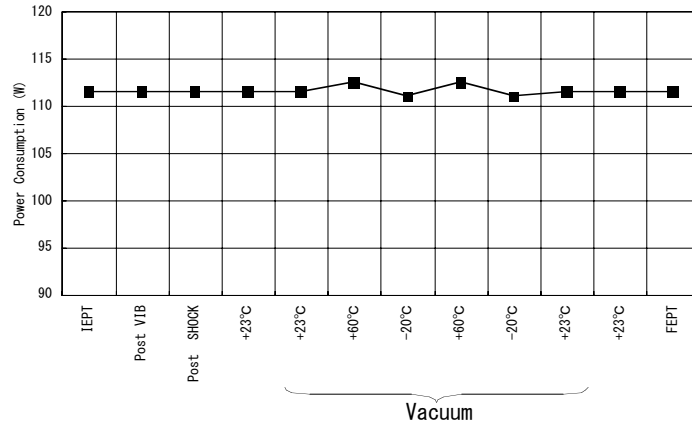

Fig. 5 Power consumption trend for DDEM EM

ii) MOD

The MOD component uses analog signal processing technology. One MOD component modulates a fixed rate (155 Mbps) data stream in a TDMA burst format. The MOD adds a unique word (UW) to the data stream, enabling the user station to detect burst signals.

It also transmits non-modulated carrier waves (CW) in the center frequency of its bandwidth or a PN-modulated continuous signal for testing purposes and has a carrier-off function to prevent the output of unnecessary signals.

In tests of this component, the MOD EM accurately performed modulation, TDMA synchronization, and addition of UWs. The tests also showed that the modulation spectrum and spurious satisfied the WINDS specification. The trends for the modulation spectrum and carrier suppression are shown in Figs. 6 and 7.

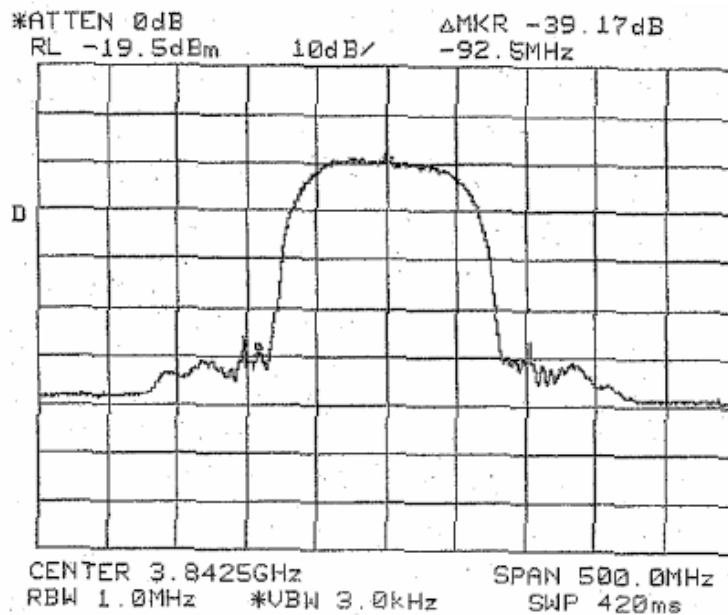

Fig. 6 Modulation spectrum for MOD EM

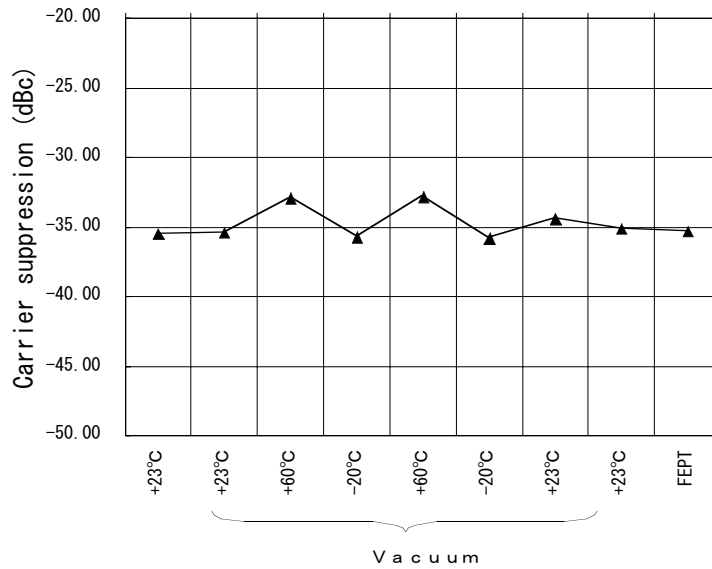

Fig. 7 Carrier suppression trend for MOD EM

This component weighs about 6 kg and has a power consumption of about 26 W. The power consumption trend is shown in Fig. 8.

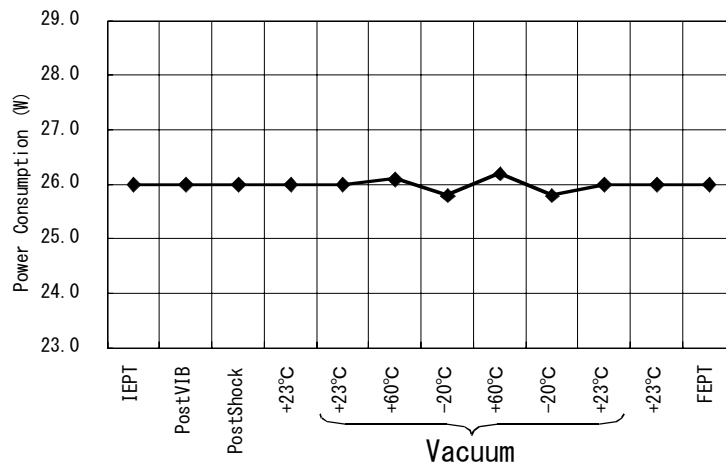

Fig. 8 Power consumption trend for MOD EM

iii) ATMS

The ATMS is designed to be compatible with widely used terrestrial ATM switches.

It has three input and output lines and the data rate for each port is equivalent to 155 Mbps. It supports two service classes: CBR and VBR. The ATMS also has a buffer memory for buffering cells. Buffering is carried out for each beam area and service class. It has a switching ability of over 435 Mbps, in accordance with the WINDS EM specification,

because the ABS has only three input/output lines. However, the actual switching capability of the ATMS is about 2.5 Gbps. A block diagram of the ATMS's functions is shown in Fig. 9.

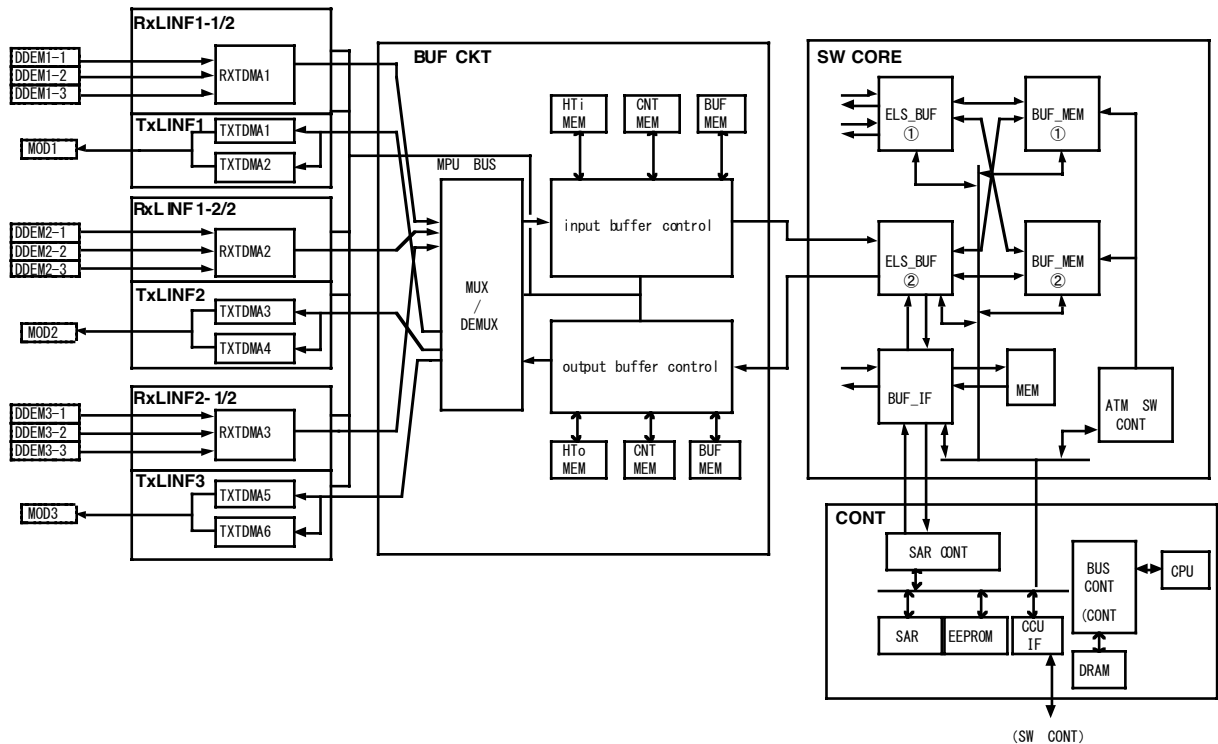

Fig. 9 Block diagram of ATMS functions

We carried out a 24-hour running test using a total data stream of 435 Mbps (145 Mbps/line \times 3), which showed that there was no ATM cell loss.

Reference bursts for frame synchronization of the user station will be generated in the ATMS, which will transmit the bursts in the first slot in each frame of a downlink.

In addition, the ATMS will have a software-loading function for updating the ABS control software.

This component weighs about 17 kg and has a power consumption of about 60 W.

Subsystem tests

i) DDEM-ATMS

We confirmed the ATM cell flow from the DDEM input port to the ATMS output line. No cell loss occurred.

ii) ATMS-MOD

The ATMS is controlled by output timing and the output line for the TDMA slot is controlled by a switch controller. We confirmed that the ATMS outputs the ATM cell at the designated line in accordance with the controller's instructions and the MOD modulated the input stream.

iii) DDEM-ATMS-MOD

We confirmed that the set-up process in the ABS subsystem combined three components. We also confirmed that the ABS subsystem (DDEM, MOD, and ATMS) operated simultaneously with no cell loss.

Conclusion

We are continuing to test the subsystem. We now plan to test a back-pressure function to manage congestion and deal with plural data rate slots. We also plan to develop a proto flight model (PFM) for WINDS using these results.

References

- [1] N. Yoshimura et al. "R & D Status of the On-Board ATM Switching Subsystem for WINDS," 23rd ISTS May 2002, 2002-j-02
- [2] N. Kadowaki, "Broadband Satellite Networking with on-Board Switching Technology." Colloquium at 21st ICSSC AIAA, Yokohama, Japan, April 2003
- [3] N. Kadowaki, N. Yoshimura, Y. Ogawa, "Development Results of the On-board ATM Switch for the WINDS," 9th Ka and Broadband Communications Conference, Ischia, Italy, November 2003